

autoFlo

**HOW
TO INSTALL,
OPERATE AND
MAINTAIN
YOUR**

**X-15 A
POWER HUMIDIFIER**

READ AND SAVE THESE INSTRUCTIONS

autoFlo

**AMERICAN METAL PRODUCTS CO., DIV. OF MASCO CORPORATION
6100 BANDINI BOULEVARD, LOS ANGELES, CALIFORNIA 90040**

Welcome to the world of the UN-DRY

The Auto-Flo Power Humidifier you have just purchased has been designed as the "ultimate automatic humidifier." It's simple . . . highly efficient . . . and amazingly easy to maintain. Like any important appliance in your home, however, a little tender care and maintenance will make it last longer and perform at its peak efficiency for years.

This picture will let you familiarize yourself with some of the features of your new Auto-Flo and their locations.

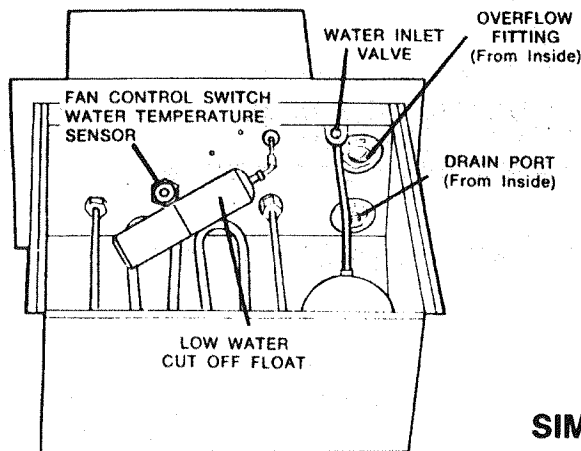
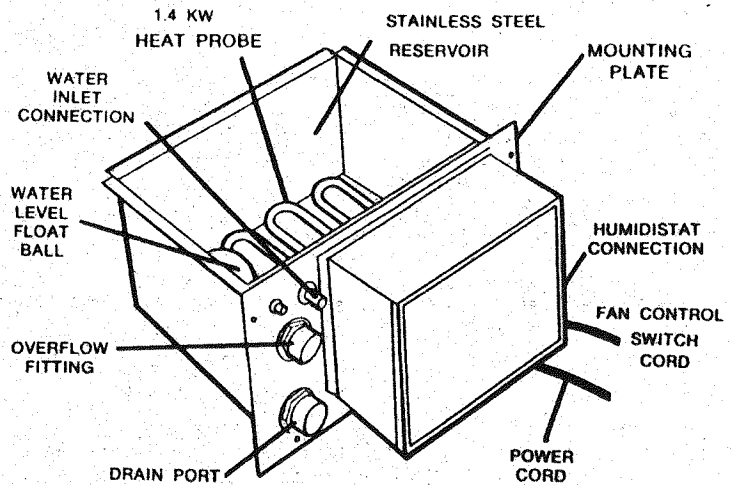

PARTS INCLUDED

1. HUMIDIFIER
2. 10' WATER TUBING
3. SELF PIERCING (IN COPPER) SADDLE VALVE
4. MOUNTING SCREWS
5. INSTALLATION AND MAINTENANCE MANUAL
6. TEMPLATE
7. PLASTIC DRAIN FITTING AND HOSE CLAMP

NOTE: This humidifier *cannot* be operated without a humidistat. Because of the wide variety of humidistats available, one is not included in this package. Humidistat must be field supplied, such as the Auto-Flo #052000 humidistat.

SIMPLIFIED INSTALLATION INSTRUCTIONS

1. Select mounting position and tape on template.
2. Punch 5 mounting holes and cut out opening on dotted line.
3. Insert reservoir into opening and screw into place.
4. Connect water line.
5. Make connection to fan control.
6. Install humidistat control.
7. Plug power cord into 110 V - 15 amp outlet.
8. Enjoy being undry.

DETAILED INSTALLATION INSTRUCTIONS

1. LOCATION

The X-15 A can be inserted into warm or cold air ducts or bonnets. Air temperature has little bearing on the unit's performance. Be certain there is room for the reservoir to fit inside the plenum or duct.

An adapter, Auto Flo part #1284 is available for an underduct installation, where too much air flow would be blocked by an "in duct" placement.

When using a supply bonnet, be sure you're missing the air conditioning coil.

2. TEMPLATE AND 3. CUTTING OPENING

Tape template against mounting location and mark opening to be cut out and 5 holes to be punched for mounting screws.

With a scratch awl or nail, punch the five mounting screw holes. Remove the metal outlined on the Template.

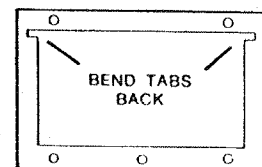

FIG. 3

Do not screw unit into place until water level is set!

4. WATER CONNECTION

NOTE: Never install a saddle valve on the bottom of a water pipe. Sediment in the pipe will clog the valve. Use the side or top if possible.

NOTE: USE COPPER TUBING (NOT FURNISHED) FOR YOUR WATER SUPPLY. DO NOT USE PLASTIC TUBING.

5. SETTING THE WATER LEVEL

CAUTION: When bending the float arm to adjust water level, *avoid pulling up on the arm*. Doing so will exert extreme pressure on the neoprene seal which stops the water flow by seating against a stainless steel orifice. The orifice will damage the seal. *Raise the water level by bending the arm down as shown in Fig. 5.*

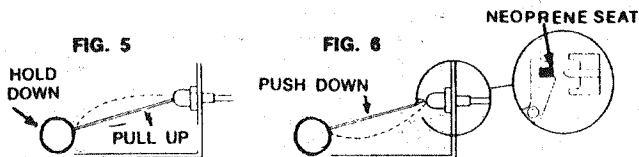

To lower the water level, hold float ball firmly down against the reservoir bottom, and pull up on the arm as shown in Fig. 6.

Different communities have different water pressures. It may be necessary to adjust the water level control to your water pressure. To do this, set your X-15 A on a table, or box, so that the reservoir is level. Attach the water line, and allow unit to fill until the float valve shuts off. The level should be approximately an inch above the heating element. If not, adjust by bending the water level float arm to raise or lower the level.

Plug the humidifier into 110V-15A outlet, and short across the low voltage humidistat terminals. The relay should click and the red indicator light should come on. Depress the low water float. Well before it touches the heat element, the relay should click and the red light should go off. Release the float and the relay should click on . . . the red light should come back on . . . indicating a return to normal operation.

6. MOUNTING UNIT

Insert the reservoir into the opening and secure with the 5 sheet metal screws.

7. WIRING THE HUMIDIFIER

NOTE: The X-15 A must be installed in a location so that connections can be made to the power source without the use of an extension cord.

All wiring must be done in accordance with local codes and ordinances.

Because of the high capacity output of the X-15 A, it must not be operated in ducts or plenums without the system blower running. Severe condensation problems would result.

Therefore, an automatic switch is built into the reservoir to sense water temperature. This switch will click "ON" when the water in the reservoir reaches 170° F (77° C) and will click "OFF" when the temperature drops back to 120° F (48° C).

This automatic switch can be utilized in various ways to automatically activate the system blower, whenever humidity is needed. Regardless of whether or not heating (or cooling) is in operation. Some of these methods are shown here.

Typical Fan Control Connections

A. If the system blower is set for constant "ON," no further wiring needs to be done. However, the installation of a "sail" switch in the low voltage humidistat circuit is recommended, to avoid problems if the user should manually turn the blower off.

B. If the X-15 A is being installed in a gas or oil-fired furnace system, make the connection to the fan-limit switch.

Connections to the fan limit switch on the furnace may be made as shown in Figure 8 below with No. 16 AWG wire.

Male and female connectors are provided to allow disconnect for maintenance.

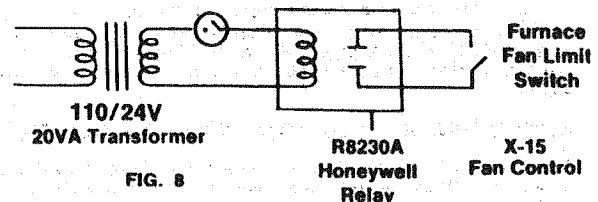

C. In a system with air conditioning, make the connection to the fan-relay switch. This is a low voltage connection.

CAUTION: Activating the fan-relay, on some systems, will also operate the air conditioner compressor. Severe damage to the compressor can result if it is started in cold weather. Wire a R8225C relay (not supplied) into the low voltage circuit to compressor, to automatically deactivate it during the X-15 A operating cycle. (See Fig. 9) Here is a typical diagram of such an installation.

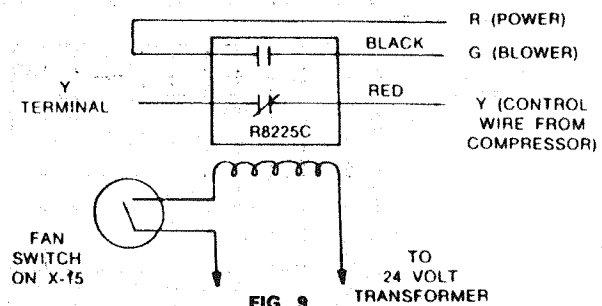

8. WIRING THE HUMIDISTAT

The humidistat controller is usable on either the wall, or on a *return air* duct. The instructions for mounting it are packed with it. Two low voltage (24V) contacts are located on the right side of the X-15 A cover. Attach "thermostat" wire and connect to humidistat.

IMPORTANT: When X-15 A is mounted in return air duct or bonnet, humidistat must be located at least 3 feet *upstream*, so output of humidifier does not abnormally affect operation.

9. OPERATION AND MAINTENANCE

When your humidistat calls for moisture, the X-15-A will start heating the water in the reservoir. The red signal light will be on to indicate the heat element is on. In a few minutes, the water temperature will start the blower of your system to distribute the moisture. When the set humidity level has been reached, the heat element will be turned off. The signal light will also go off. The blower will remain on until the water temperature in the reservoir has cooled. The blower will then be turned off to complete the cycle. If your blower runs constantly, as it should if you have an electronic air cleaner, the fan will not be turned on and off by the X-15 A.

It's recommended that your humidistat be kept no higher than 30-40%. Lower than that, if condensation becomes a problem in colder weather.

Maintenance of your X-15 A is simple. Once yearly is sufficient in soft water areas . . . *more often in harder water areas.*

Removal of accumulated minerals is the only necessary chore. Here are the steps involved:

1. Unplug power cord 30 minutes before starting maintenance, to be sure water in reservoir is not hot.
2. Remove two humidistat leads.
3. Disconnect fan control cord.
4. Turn water supply off.
5. Remove drain cap and drain water into bucket.
6. Remove 5 screws from around flange.
7. Slide X-15 A out of opening.

You will find a coating of mineral on the inside of the reservoir that can be "peeled" from sides and bottom with a putty knife. Don't be concerned if some sticks on it. There will be a collection of loose "chips" under the heat element. They rinse out easily. Gently scrape off any lime on the float ball, and the low water cut-off float.

8. Rinse the reservoir out and replace the unit.

CAUTION: Lack of proper cleaning can allow lime chips and coating to block the "fall" of the low-water cut-off float. This can allow the heat probe to operate in air . . . *destroying it.*

HOW OFTEN SHOULD YOUR X-15 A BE CLEANED?

Like humidity, it's relative . . . relative to how "hard" your water is. Relative to how high you set the control. Relative to the size of your home.

Here is a guideline for your home. This chart (Fig. 10) shows quite precisely how much "lime" the X-15 A will make in different water conditions, after an actual operating time of 1000 hrs.

The X-15 A can operate successfully with up to 2½ lbs. of "lime" in it. As you can see, the "harder" the water the more lime generated. Call your water dept. for the "grains" of hardness in your area. A water softener does not remove lime . . . only changes its form. The cleaning schedule will remain the same. An occasional draining of the reservoir between "cleaning" will help slow down the accumulation.

"If your X-15 A runs an average of 12 hrs. per day . . . it would take 83 days to accumulate 1000 hrs. . . almost 3 months. This would cover the bulk of the heavy heating season in most areas.

FIG. 10

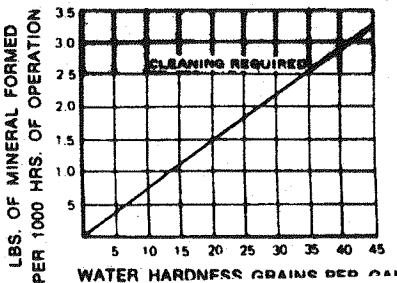

IMPORTANT

X-15 A SIZING INFORMATION

To make certain that the lime which forms on the X-15 A heat element is allowed to "chip off", it is essential that the element be allowed to cool off several times a day. It is the heating-cooling, expansion-contraction action which chips the lime. Therefore, if the X-15 A is installed in a space too large for it, or higher than normal humidities are called for, it will be heating continuously during colder weather, building up a thicker and thicker coating of mineral . . . to its certain detriment.

Here are some rough rules to follow:

Gas or oil fired furnace.

Comfortable R.H. setting up to 1400 sq. ft. (app. 11,000 cu. ft.)

Electric furnace or heat pump:

Comfortable R.H. setting up to 2800 sq. ft. (app. 22,000 cu. ft.)

If a higher humidity level is needed, or larger space is involved, use an additional unit (or units). Be aware, however, that an undersized installation will not allow the set humidity level to be reached in the colder weather . . . even though the X-15 A is running at its maximum output.

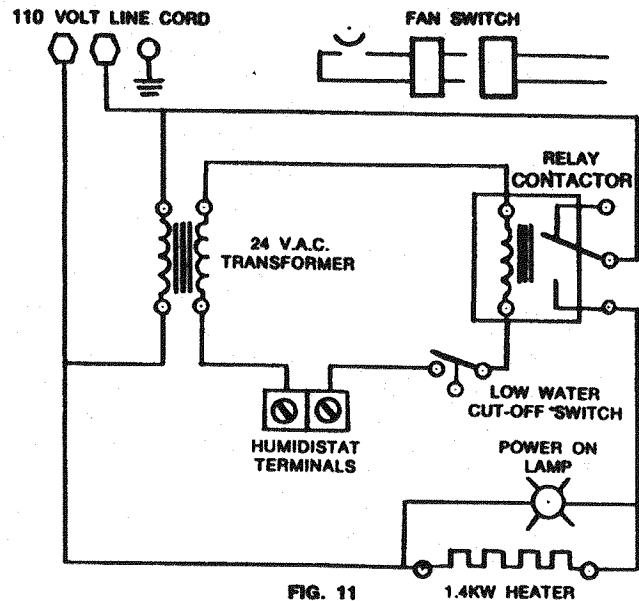

FIG. 11

X-15 A WIRING DIAGRAM

PARTS LIST

1583—1.4Kw Heat Element	1581—Fan Control Switch
1521—Water Level Float Assembly	1524—Indicating Light
1534—Low Water Cut Off Float Assembly	1549—Relay Contactor
5503—Low Water Level Micro Switch	1527—Stainless Steel Reservoir
1562—Transformer	1592—Mounting Plate
	1233—Front Cover Assembly

autoflo®

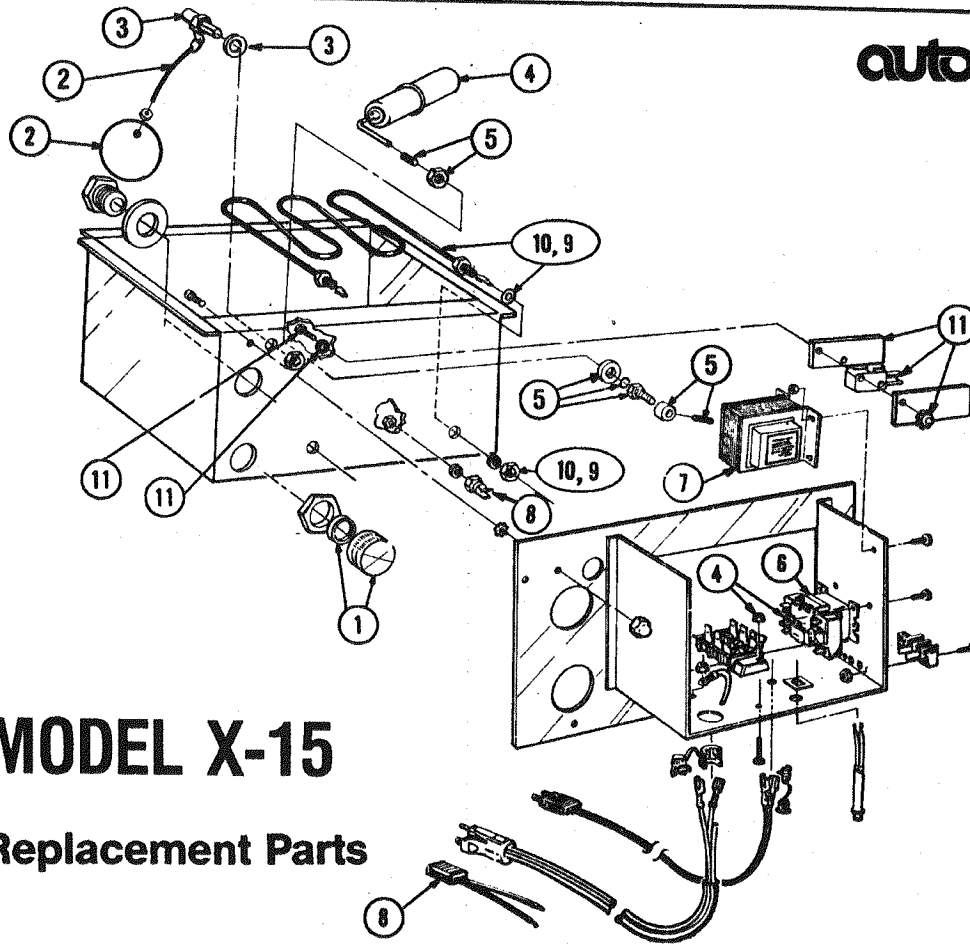

MODEL X-15

Replacement Parts

Item#	Qty.	Description	Part #
1	1	Drain Cap/Gasket	1506
2	1	Ball Float & Arm	401494
		Consists of:	
		1 - Ball Float	
		1 - Arm	
3	1	Ball Float/Valve Assembly	1521
		Consists of:	
		1 - #2 (401494 - Above)	
		1 - Valve	
		1 - Seal Washer	
		1 - Nut	
4	1	Low Level Float & Arm	1573
		Consists of:	
		1 - Low Level Float	
		1 - Arm	
5	1	Low Level Float Assy.	1534
		Consists of:	
		1 - #4 (1573 - Above)	
		1 - Nut	
		2 - Washers	
		1 - Panel Bearing	
		1 - O Ring	
		1 - Shaft Collar	
		1 - Set Screw	
6	1	24 Volt Relay Assy.	1549
		Consists of:	
		1 - 24V Relay	
		2 - Screws	

Item#	Qty.	Description	Part #
7	1	120V/24V Transformer Assembly	1562A
		220/24V Transformer Assembly	1562B
8	1	Fan Switch Assembly	1581-1
		Consists of:	
		1 - Fan Switch	
		1 - Washer	
		1 - Nut	
9	1	Heater Assembly, 1400W, 120V	1583
		Consists of:	
		1 - Heater	
		2 - Washers	
		2 - Nuts	
10	1	Heater Assembly, 2000W, 220V	1278
		Consists of:	
		1 - Heater	
		2 - Washers	
		2 - Nuts	
11	1	Microswitch Assembly	5503
		Consists of:	
		1 - Switch	
		2 - Insulators	
		2 - Bolts	
		2 - Washers	
		2 - Nuts	